

## Umbrella Inserts and Stubby Screens

**High Performance Adhesive Systems for Fastening to the Front Face of Hollow Base Materials**

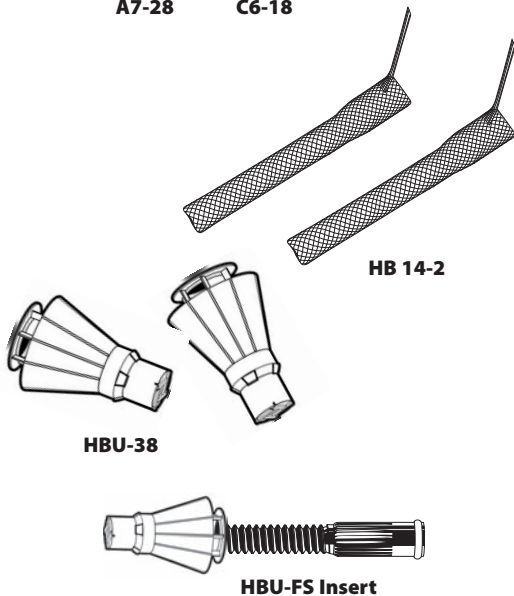

**A7-28 C6-18**



**HBU-38**

**HBU-FS Insert**

### Hollow Block Fastening with A7 and C6 Adhesive

#### HBU-38

Umbrella Inserts—specially designed for fastening to the face of hollow concrete block, brick, clay tile or terra cotta. Accepts rods between 1/4" and 1/2"

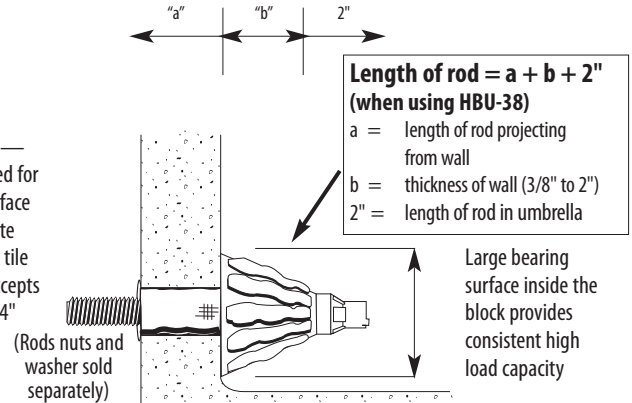

#### HBU-FS

Umbrella Inserts with 3/8" internally threaded sleeve. Removable fastening to concrete block

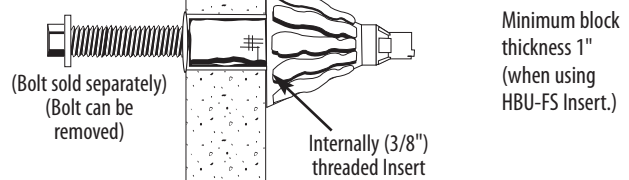

#### STUBBY SCREENS

Specially designed stainless steel screens provide maximum performance for a screen in the front face of hollow concrete block. Screens available for rods 1/4" to 5/8"

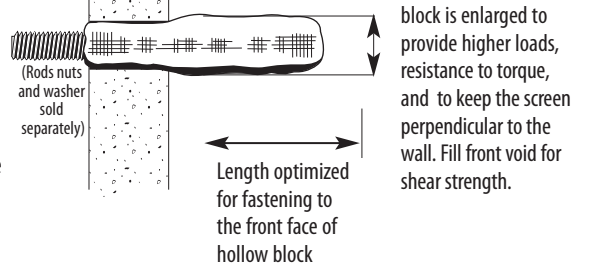

**Section View—Face Concrete Block**

## INSTALLATION STEPS

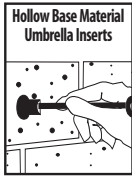

1. Drill 3/4" diameter hole, 3-3/4" deep using rotation only drilling mode and carbide tipped drill bit. Clean out hole with forced air. Complete hole preparation with use of a brush and repeat cleaning with compressed air (leave no dust or slurry).

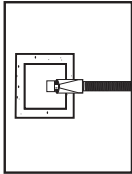

2. Place umbrella on piece of threaded rod, stretch umbrella over the rod by pulling the white collar back approximately 1". Squeeze orange portion of umbrella and push umbrella into hole.

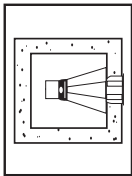

3. Push umbrella body through the hole and completely into void. Remove threaded rod. (Do not use in solid base materials. For anchoring into block web, ends and mortar joints, use screens.) View and verify umbrella wings expanded behind wall.

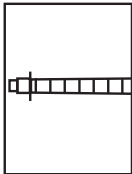

4. Place hole plug (E038) 1/8" from end of self-mixing adhesive nozzle.

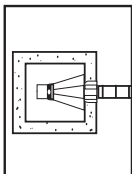

5. Dispense and discard a sufficient amount of adhesive from new cartridge until a uniform adhesive mix is achieved. Inject approximately 1-1/2 fl. oz. of adhesive into umbrella (7 to 8 pumps using manual dispenser) to completely fill umbrella.

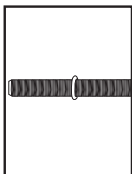

6. 3/8" rod uses a centering ring (supplied with inserts) to keep rod perpendicular to the wall.

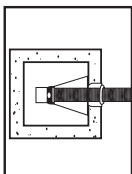

7. Insert rod into the filled umbrella using a slow, soft twisting motion until it contacts the back of umbrella.

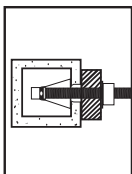



8. Wait for appropriate temperature/cure time before tightening fixture to the recommended torque of 10 ft./lbs.

Installation instructions for stubby screens provided on page 33.

## SELECTION CHART

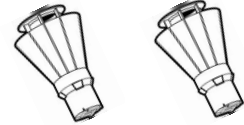
### Umbrella Inserts

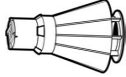

DESCRIPTION	PART NO.	BOX CONTENTS
Umbrella Anchor 	HBU-38	20 Umbrella 20 Centering Rings
3/8" Internally Threaded Insert with Umbrella 	HBU-FS	10 Umbrella 10 Flush Sleeve Inserts

## SELECTION CHART

### Stubby Screens



PART NO.	DESCRIPTION	QTY/BOX
HB 14-2	1/4" x 2" Stainless Screen	100
HB 38-312	3/8" x 3-1/2" Stainless Screen	100
HB 12-312	1/2" x 3-1/2" Stainless Screen	50
HB 58-412	5/8" x 4-1/2" Stainless Screen	50

## ESTIMATING TABLE

### Umbrella Inserts

**Number of Anchoring Installations Per Cartridge\* Using Threaded Rod and Umbrella Inserts with A7 and C6 Adhesives in Hollow Base Material**

ROD In (mm)	DRILL HOLE DIA. INCHES	VOLUME OF CARTRIDGE	UMBRELLA INSERT WITH EMBEDMENT OF 3-3/4"
3/8 (9.5)	3/4	A7 5 fluid oz.	3
		A7 8 fluid oz.	5
		A7 10 fluid oz.	6
		A7 28 fluid oz.	17
		C6 18 fluid oz.	11

\*These estimates do not account for waste.

## ESTIMATING TABLE

### Stubby Screens

Number of Anchoring Installations Per Cartridge\* Using Threaded Rod and Stubby Screens with A7 and C6 Adhesives in Hollow Base Material

ROD In (mm)	DRILL HOLE DIA. INCHES	VOLUME OF CARTRIDGE	SCREEN LENGTH (INCHES)		
			2	3-1/2	4-1/2
1/4 (6.4)	3/8	A7 8 fluid oz.	39		
		A7 10 fluid oz.	48		
		A7 28 fluid oz.	135		
		C6 18 fluid oz.	87		
3/8 (9.5)	1/2	A7 8 fluid oz.		17	
		A7 10 fluid oz.		21	
		A7 28 fluid oz.		62	
		C6 18 fluid oz.		40	
1/2 (12.7)	5/8	A7 8 fluid oz.		12	
		A7 10 fluid oz.		15	
		A7 28 fluid oz.		43	
		C6 18 fluid oz.		28	
5/8 (15.9)	3/4	A7 8 fluid oz.			7
		A7 10 fluid oz.			11
		A7 28 fluid oz.			24
		C6 18 fluid oz.			16

\* These estimates do not account for waste.

### Load Values<sup>1,2</sup>

Using A7 in Hollow Concrete Block

	ROD DIA. In. (mm)	MAX CLAMPING FORCE AFTER PROPER CURE Ft.-Lbs. (Nm)	DRILL HOLE DIA. In. (mm)	EMBEDMENT (SCREEN LENGTH) In. (mm)	ULTIMATE TENSION Lbs. (Kn)	ULTIMATE SHEAR Lbs. (Kn)
Umbrella	3/8 (9.5)	10 (13)	3/4 (19.1)	3-3/4 (95.3)	3,558 (15.8)	3,109 (13.8)
Stubby Screens	1/4 (6.4)	4 (5)	3/8 (9.5)	2 (50.8)	1,550 (6.9)	1,900 (8.5)
	3/8 (9.5)	7 (9)	1/2 (12.7)	3-1/2 (88.9)	1,661 (7.4)	2,071 (9.2)
	1/2 (12.7)	10 (13)	5/8 (15.9)	3-1/2 (88.9)	2,458 (10.9)	4,467 (19.9)
	5/8 (15.9)	13 (17)	3/4 (19.1)	4-1/2 (114.3)	2,543 (10.9)	5,047 (22.4)

1 Allowable working loads should not exceed 25% ultimate capacity. Based upon testing using ASTM A193, Grade B7 rod.

2 The tabulated values are for anchors installed at a minimum 12 inch edge distance and minimum 8 inch spacing.

### Load Values<sup>1,2</sup>

Using C6 in Hollow Concrete Block

	ROD DIA. In. (mm)	MAX CLAMPING FORCE AFTER PROPER CURE Ft.-Lbs. (Nm)	DRILL HOLE DIA. In. (mm)	EMBEDMENT (SCREEN LENGTH) In. (mm)	ULTIMATE TENSION Lbs. (Kn)	ULTIMATE SHEAR Lbs. (Kn)
Umbrella	3/8 (9.5)	10 (13)	3/4 (19.1)	3-3/4 (95.3)	1,875 (8.3)	2,200 (9.8)
Stubby Screens	1/4 (6.4)	4 (5)	3/8 (9.5)	2 (50.8)	1,550 (6.9)	1,900 (8.5)
	3/8 (9.5)	7 (9)	1/2 (12.7)	3-1/2 (88.9)	1,661 (7.4)	2,071 (9.2)
	1/2 (12.7)	10 (13)	5/8 (15.9)	3-1/2 (88.9)	1,873 (8.3)	2,242 (10.0)
	5/8 (15.9)	13 (17)	3/4 (19.1)	4-1/2 (114.3)	1,970 (8.8)	3,554 (15.8)

1 Allowable working loads should not exceed 25% ultimate capacity. Based upon testing using ASTM A193, Grade B7 rod.

2 The tabulated values are for anchors installed at a minimum 12 inch edge distance and minimum 8 inch spacing.