

A7 Adhesive



Fast Dispensing, Fast Curing Acrylic Adhesive

The acrylic resin and hardening agent are completely mixed as they are simultaneously dispensed from the dual cartridge through a static mixing nozzle, directly into the anchor hole. A7 can be used with threaded rod or rebar (for fastening to hollow base materials, see pages 30 and 33).



ADVANTAGES

- All weather formula, down to 0°F and below
- No drip, no sag, easy clean up
- Fast & easy dispensing, even 28-oz. cartridges can be hand dispensed
- Fast curing time, 35 minutes at 60°F
- Not mix ratio sensitive
- NSF 61 Approved
- Rods are easier to insert into the hole with A7 compared with other adhesives
- Works in damp holes and underwater applications
- Requires less adhesive—can be used in 1/16" oversized or 1/8" oversized holes
- **One formula** for both hollow and solid base materials

Curing Times

BASE MATERIAL TEMPERATURE (F°/C°)	WORKING TIME	FULL CURE TIME
100° / 38°	5 minutes	25 minutes
80° / 27°	5.5 minutes	30 minutes
60° / 16°	7 minutes	35 minutes
40° / 4°	15 minutes	75 minutes
20° / -7°	35 minutes	6 hours
0° / -18°	4 hours	24 hours

INSTALLATION STEPS

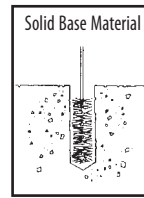

1. Drill 1/16" oversized diameter holes for 1/4"–1/2" diameter threaded rods and #3 rebar. Drill 1/8" oversized diameter holes for 5/8"–1-1/4" diameter threaded rods, #4 rebar, grout filled blocks and brick pinning. Clean out hold from bottom with forced air. Complete hole preparation with brush and repeat cleaning with forced air (leave no dust or slurry).

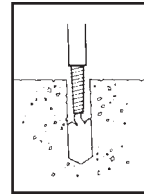

2. When starting new cartridge or new nozzle, dispense and discard enough adhesive until uniform grey color is achieved. Insert the nozzle into the bottom of the hole and fill to 1/2 the hole depth.

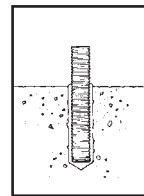

3. Insert rod slowly by hand into the bottom of the hole with a slow twisting motion. This insures adhesive fills voids and crevices and uniformly coats the anchor rod.

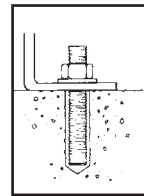

4. See table for working times and curing times. After the suggested cure time is met, install and tighten fixture into place.



Certified to ANSI/NSF 61

APPROVALS/LISTINGS





- ASTM C881, Type IV, Grade 3, Class A, B, C (exceptions - A7 gels faster than ASTM requirements and does not contain any epoxy)
- ICC Evaluation Service, Inc. – #ER-5560 (formerly ICBO)
- ICC-ES Report – ESR 2351
- Metro-Dade County – #06-0425.02
- City of Los Angeles – RR#25379
- DOT Approvals
- Florida Building Code

SUGGESTED SPECIFICATIONS

PACKAGING:

1. Disposable, self-contained cartridge system capable of dispensing both components in the proper mixing ratio
2. Acrylic components dispensed through a static mixing nozzle that thoroughly mixes the material and places the material at the base of the pre-drilled hole
3. Cartridge markings: Include manufacturer's name, batch number and best-used-by date, mix ratio by volume, ANSI hazard classification, and appropriate ANSI handling precautions

A7—28 fl. oz. Ordering Information

PART NUMBER	DESCRIPTION	BOX QTY
 A7-28	28 Fluid Ounce Cartridge A7	4
 E55	Mixing Nozzle for A7-28 and G5-22 Cartridge Nozzle diameter from 3/8" to 5/8" (overall length of nozzle 17")	24
 A102	<i>Largest hand dispensable cartridge— still easy to dispense</i> Hand Dispenser for A7-28 Cartridge	1
 A200	Pneumatic Dispenser for A7-28 Cartridge	1

ESTIMATING TABLE

A7 Number of Anchoring Installations per Cartridge* 28 Fluid Ounce Cartridge Using Reinforcing Bar with A7 Adhesive in Solid Concrete

REBAR	DRILL HOLE DIA. INCHES	EMBEDMENT DEPTH IN INCHES (mm)														
		1 (25.4)	2 (50.8)	3 (76.2)	4 (101.6)	5 (127.0)	6 (152.4)	7 (177.8)	8 (203.2)	9 (228.6)	10 (254.0)	11 (279.4)	12 (304.8)	13 (330.2)	14 (355.6)	15 (381.0)
# 3	7/16	662.5	331.3	220.8	165.6	132.5	110.4	94.6	82.8	73.6	66.3	60.2	55.2	51.0	47.3	44.2
# 4	5/8	373.0	186.5	124.3	93.2	74.6	62.2	53.3	46.6	41.4	37.3	33.9	31.1	28.7	26.6	24.9
# 5	3/4	286.1	143.0	95.4	71.5	57.2	47.7	40.9	35.8	31.8	28.6	26.0	23.8	22.0	20.4	19.1
# 6	7/8	231.0	115.5	77.0	57.7	46.2	38.5	33.3	28.8	25.7	23.1	21.0	19.2	17.8	16.5	15.4
# 7	1	213.4	106.7	71.1	53.3	42.7	35.6	30.5	26.7	23.7	21.3	19.4	17.8	16.4	15.2	14.2
# 8	1-1/8	177.3	88.6	59.1	44.3	35.5	29.5	25.3	22.2	19.7	17.7	16.1	14.8	13.6	12.7	11.8
# 9	1-1/4	102.8	51.4	34.3	25.7	20.6	17.1	14.7	12.8	11.4	10.3	9.3	8.6	7.9	7.3	6.9
# 10	1-1/2	84.1	42.0	28.0	21.0	16.8	14.0	12.0	10.5	9.3	8.4	7.6	7.0	6.5	6.0	5.6
# 11	1-3/4	51.4	25.7	17.1	12.8	10.3	8.6	7.3	6.4	5.7	5.1	4.7	4.3	4.0	3.7	3.4

* The number of anchoring installations is based upon calculations of hole volumes using ANSI tolerance carbide tipped drill bits, the nominal areas of the reinforcing bars and the stress areas of the threaded rods. These estimates do not account for waste.

ESTIMATING TABLE



SETTING TORQUES PROVIDED ON PAGE 10

A7 Number of Anchoring Installations per Cartridge* 28 Fluid Ounce Cartridge Using Threaded Rod with A7 Adhesive in Solid Concrete

ROD In. (mm)	DRILL HOLE DIA. INCHES	EMBEDMENT DEPTH IN INCHES (mm)														
		1 (25.4)	2 (50.8)	3 (76.2)	4 (101.6)	5 (127.0)	6 (152.4)	7 (177.8)	8 (203.2)	9 (228.6)	10 (254.0)	11 (279.4)	12 (304.8)	13 (330.2)	14 (355.6)	15 (381.0)
1/4 (6.4)	5/16	915.5	457.7	305.2	228.9	183.1	152.8	130.8	114.4	101.7	91.5	83.2	76.3	70.4	65.4	61.0
3/8 (9.5)	7/16	530.0	265.0	176.7	132.5	106.0	88.3	75.7	66.3	58.9	53.0	48.2	44.2	40.8	37.9	35.3
1/2 (12.7)	9/16	381.4	190.7	127.1	95.4	76.3	63.6	54.5	47.7	42.4	38.1	34.7	31.8	29.3	27.2	25.4
5/8 (15.9)	11/16 3/4	273.6 195.6	136.8 97.8	91.2 65.1	68.4 48.8	54.7 39.0	45.6 32.5	39.1 27.9	34.2 24.4	30.4 21.7	27.4 19.5	24.9 17.7	22.8 16.3	21.0 15.0	19.5 13.9	18.2 13.0
3/4 (19.1)	13/16 7/8	192.9 154.4	96.5 77.2	64.3 51.5	48.2 38.6	38.6 30.9	32.2 25.7	27.6 22.1	24.1 19.3	21.4 17.2	19.3 15.4	17.5 14.0	16.1 12.9	14.8 11.9	13.8 11.0	12.9 10.3
7/8 (22.2)	15/16 1	185.1 128.0	92.6 64.0	61.7 42.8	46.3 32.0	37.0 25.6	30.9 21.4	26.8 18.3	23.1 16.0	20.6 14.2	18.5 12.8	16.8 11.6	15.4 10.7	14.2 9.9	13.2 9.2	12.3 8.5
1 (25.4)	1 - 1/16 1 - 1/8	158.3 105.2	79.2 52.6	52.8 35.2	39.6 26.3	31.7 21.1	26.4 17.6	22.6 15.0	19.8 13.2	17.6 11.7	15.8 10.5	14.4 9.6	13.2 8.8	12.2 8.1	11.3 7.6	10.6 7.0
1-1/4 (31.8)	1 - 5/16 1 - 3/8	101.3 80.0	50.7 40.0	33.8 26.6	25.3 20.0	20.3 15.9	16.9 13.3	14.5 11.4	12.7 10.0	11.3 8.9	10.1 8.0	9.2 7.2	8.4 6.6	7.8 6.1	7.2 5.7	6.8 5.3

* The number of anchoring installations is based upon calculations of hole volumes using ANSI tolerance carbide tipped drill bits, the nominal areas of the reinforcing bars and the stress areas of the threaded rods. These estimates do not account for waste.

A7—10 fl. oz. Ordering Information

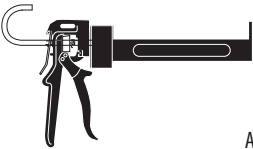
PART NUMBER	DESCRIPTION	BOX QTY
 A7-10	9.3 Fluid Ounce Cartridge with Nozzle	6
 A24	Mixing Nozzle for A7-10 Cartridge Nozzle diameter from 3/8" to 5/8" (overall length of nozzle 6-3/8")	24
 A100	Hand Dispenser Designed for A7-10 Cartridge Contractor Quality 26:1 Thrust Ratio	1

SUGGESTED SPECIFICATIONS

ACRYLIC ADHESIVE:

- Two component methyl methacrylate adhesive, non-sag paste, moisture insensitive when cured, dark gray in color
- Meets ASTM C881-90, Type IV, Grade 3, Class A, B, and C with the exception of gel time and epoxy content
- Shrinkage during cure per ASTM D2566: .002in./in.
- Heat deflection temperature, ASTM D648: 140°F minimum
- Shelf life: Best if used within 18 months
- Pumpable at 0°F without preheating

ESTIMATING TABLES

A7 10 Fluid Ounce Cartridge



Number of Anchoring Installations per Cartridge* Using Reinforcing Bar and Threaded Rod with A7 Adhesive in Solid Concrete

REBAR	DRILL HOLE DIA. INCHES	EMBEDMENT DEPTH IN INCHES (mm)			
		2 (50.8)	4 (101.6)	6 (152.4)	8 (203.2)
# 3	7/16	110	55	37	27
# 4	5/8	63	31	20	14
# 5	3/4	48	24	16	11
# 6	7/8	39	18	13	9
# 7	1	35	18	11	9
# 8	1-1/8	29	14	9	7

ROD In (mm)	DRILL HOLE DIA. INCHES	EMBEDMENT DEPTH IN INCHES (mm)			
		2 (50.8)	4 (101.6)	6 (152.4)	8 (203.2)
3/8 (9.5)	7/16	88	44	28	22
1/2 (12.7)	9/16	65	31	22	16
5/8 (15.9)	11/16	46	22	14	11
	3/4	33	16	11	7
3/4 (19.1)	13/16	33	16	11	7
	7/8	26	13	9	7
7/8 (22.2)	15/16	31	14	11	7
	1	22	11	7	5
1 (25.4)	1-1/16	26	13	9	7
	1-1/8	18	9	5	3

* The number of anchoring installations is based upon calculations of hole volumes using ANSI tolerance carbide tipped drill bits, the nominal areas of the reinforcing bars and the stress areas of the threaded rods. These estimates do not account for waste.

A7—8 fl. oz. Ordering Information

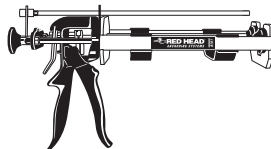
PART NUMBER	DESCRIPTION	BOX QTY
 A7-8	Fits Hilti® P2000 dispensing tools 8 Fluid Ounce Cartridge A7	6
 A24	Mixing Nozzle for A7-10 Cartridge Nozzle diameter from 3/8" to 5/8" (overall length of nozzle 6-3/8")	24
 A101	Heavy-Duty Hand Dispenser for A7-8 Cartridge	1

Hilti® P2000 is a registered trademark of the Hilti Corp.

ESTIMATING TABLE

A7 Number of Anchoring Installations per Cartridge* 8 Fluid Ounce Cartridge Using Reinforcing Bar with A7 Adhesive in Solid Concrete

REBAR	DRILL HOLE DIA. INCHES	EMBEDMENT DEPTH IN INCHES (mm)														
		1 (25.4)	2 (50.8)	3 (76.2)	4 (101.6)	5 (127.0)	6 (152.4)	7 (177.8)	8 (203.2)	9 (228.6)	10 (254.0)	11 (279.4)	12 (304.8)	13 (330.2)	14 (355.6)	15 (381.0)
# 3	7/16	187.8	93.9	62.6	46.9	37.6	31.3	26.8	23.5	20.9	18.8	17.1	15.6	14.4	13.4	12.5
# 4	5/8	105.7	52.9	35.2	26.4	21.1	17.6	15.1	13.2	11.7	10.6	9.6	8.8	8.1	7.6	7.0
# 5	3/4	81.1	40.5	27.0	20.3	16.2	13.5	11.6	10.1	9.0	8.1	7.4	6.8	6.2	5.8	5.4
# 6	7/8	65.5	32.7	21.8	16.4	13.1	10.9	9.4	8.2	7.3	6.5	6.0	5.5	5.0	4.7	4.4
# 7	1	60.5	30.2	20.2	15.1	12.1	10.1	8.6	7.6	6.7	6.0	5.5	5.0	4.7	4.3	4.0
# 8	1-1/8	50.2	25.1	16.7	12.6	10.0	8.4	7.2	6.3	5.6	5.0	4.6	4.2	3.9	3.6	3.3
# 9	1-1/4	29.1	14.6	9.7	7.3	5.8	4.9	4.2	3.6	3.2	2.9	2.6	2.4	2.2	2.1	1.9
# 10	1-1/2	23.8	11.9	7.9	6.0	4.8	4.0	3.4	3.0	2.6	2.4	2.2	2.0	1.8	1.7	1.6
# 11	1-3/4	14.6	7.3	4.9	3.6	2.9	2.4	2.1	1.8	1.6	1.5	1.3	1.2	1.1	1.0	1.0

*The number of anchoring installations is based upon calculations of hole volumes using ANSI tolerance carbide tipped drill bits, the nominal areas of the reinforcing bars and the stress areas of the threaded rods. These estimates do not account for waste.

ESTIMATING TABLE

SETTING TORQUES PROVIDED ON PAGE 10



A7 Number of Anchoring Installations per Cartridge* 8 Fluid Ounce Cartridge Using Threaded Rod with A7 Adhesive in Solid Concrete

ROD In. (mm)	DRILL HOLE DIA. INCHES	EMBEDMENT DEPTH IN INCHES (mm)														
		1 (25.4)	2 (50.8)	3 (76.2)	4 (101.6)	5 (127.0)	6 (152.4)	7 (177.8)	8 (203.2)	9 (228.6)	10 (254.0)	11 (279.4)	12 (304.8)	13 (330.2)	14 (355.6)	15 (381.0)
1/4 (6.4)	5/16	259.5	129.7	86.5	64.9	51.9	43.2	37.1	32.4	28.8	25.9	23.6	21.6	20.0	18.5	17.3
3/8 (9.5)	7/16	150.2	75.1	50.1	37.6	30.0	25.0	21.5	18.8	16.7	15.0	13.7	12.5	11.6	10.7	10.0
1/2 (12.7)	9/16	108.1	54.1	36.0	27.0	21.6	18.0	15.4	13.5	12.0	10.8	9.8	9.0	8.3	7.7	7.2
5/8 (15.9)	11/16	77.6	38.8	25.9	19.4	15.5	12.9	11.1	9.7	8.6	7.8	7.1	6.5	6.0	5.5	5.2
	3/4	55.4	27.7	18.4	13.8	11.1	9.2	7.9	6.9	6.1	5.5	5.0	4.6	4.3	4.0	3.7
3/4 (19.1)	13/16	54.7	27.3	18.2	13.7	10.9	9.1	7.8	6.8	6.1	5.5	5.0	4.6	4.2	3.9	3.6
	7/8	43.6	21.8	14.6	10.9	8.8	7.3	6.3	5.5	4.9	4.4	4.0	3.6	3.4	3.1	2.9
7/8 (22.2)	15/16	52.5	26.2	17.5	13.1	10.5	8.7	7.5	6.6	5.8	5.2	4.8	4.4	4.0	3.7	3.5
	1	36.4	18.2	12.2	9.1	7.3	6.1	5.2	4.5	4.0	3.6	3.3	3.0	2.8	2.6	2.4
1 (25.4)	1-1/16	44.9	22.4	15.0	11.2	9.0	7.5	6.4	5.6	5.0	4.5	4.1	3.7	3.5	3.2	3.0
	1-1/8	34.4	17.2	12.0	8.6	7.5	6.0	5.0	4.3	3.7	3.3	3.0	2.7	2.5	2.3	2.1
1-1/4 (31.8)	1-5/16	28.7	14.4	9.6	7.2	5.7	4.8	4.1	3.6	3.2	2.9	2.6	2.4	2.2	2.1	1.9
	1-3/8	22.4	11.2	7.6	5.6	4.5	3.8	3.2	2.8	2.5	2.3	2.1	1.9	1.7	1.6	1.5

*The number of anchoring installations is based upon calculations of hole volumes using ANSI tolerance carbide tipped drill bits, the nominal areas of the reinforcing bars and the stress areas of the threaded rods. These estimates do not account for waste.

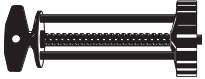
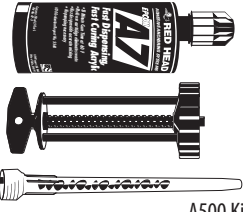
A7—5 fl. oz. Ordering Information

PART NUMBER	DESCRIPTION	BOX QTY
 A7-5	5 Fluid Ounce Cartridge A7	12
 A500	Reusable Plastic Dispenser	12
 A500 Kit	Convenient Dispensing Kit Packaged in a Solid Plastic Shell with (1) A500 Plastic Dispenser (1) A7-5 Cartridge and (1) A24 Nozzle	8

PART NUMBER	DESCRIPTION	BOX QTY
 A7-5	5 Fluid Ounce Cartridge A7	12
 A501	Reusable Caulking Gun Adaptor	12
 A501 Kit	Convenient Dispensing Kit Packaged in a Solid Plastic Shell with (1) A501 Caulking Gun Adaptor (1) A7-5 Cartridge and (1) A24 Nozzle	8

A500 PLASTIC DISPENSER

Attaches directly to cartridge allowing for easy hand dispensing.
No extra tools are required.



Simple Assembly and Dispensing

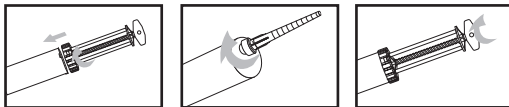

1. Twist-lock dispenser onto cartridge.
2. Thread nozzle onto cartridge.
3. Turn lever in order to dispense adhesive.



A500 Kit

A501 CAULKING GUN ADAPTOR

Allows cartridge to work with most standard caulking guns (caulking gun supplied by contractor).

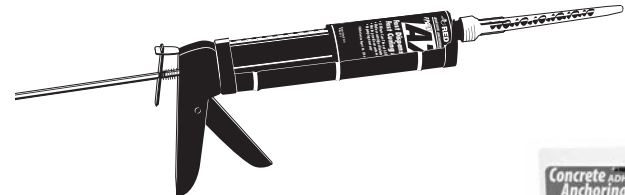

Simple Assembly and Dispensing

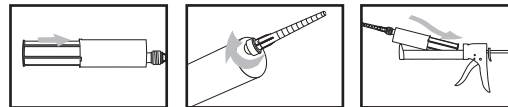

1. Push adaptor tightly against back of cartridge.
2. Thread nozzle onto cartridge.
3. Place assembly in caulking gun and dispense adhesive.



A501 Kit

ESTIMATING TABLES

A7 Number of Anchoring Installations per Cartridge* Using Reinforcing 5 Fluid Ounce Cartridge Bar and Threaded Rod with A7 Adhesive in Solid Concrete

REBAR	DRILL HOLE DIA. INCHES	EMBEDMENT DEPTH IN INCHES (mm)				ROD In (mm)	DRILL HOLE DIA. INCHES	EMBEDMENT DEPTH IN INCHES (mm)			
		2 (50.8)	4 (101.6)	6 (152.4)	8 (203.2)			2 (50.8)	4 (101.6)	6 (152.4)	8 (203.2)
# 3	7/16	60	30	20	15	3/8 (9.5)	7/16	48	24	16	12
# 4	5/8	34	17	11	8	1/2 (12.7)	9/16	35	17	12	9
# 5	3/4	26	13	9	6	5/8 (15.9)	11/16	25	12	8	6
# 6	7/8	21	10	7	5		3/4	18	9	6	4
# 7	1	19	10	6	5	3/4 (19.1)	13/16	18	9	6	4
# 8	1-1/8	16	8	5	4		7/8	14	7	5	4
						7/8 (22.2)	15/16	17	8	6	4
							1	12	6	4	3
						1 (25.4)	1-1/16	14	7	5	4
							1-1/8	10	5	3	2

* The number of anchoring installations is based upon calculations of hole volumes using ANSI tolerance carbide tipped drill bits, the nominal areas of the reinforcing bars and the stress areas of the threaded rods. These estimates do not account for waste.

PERFORMANCE TABLE

A7 Acrylic Adhesive Average Ultimate Tension and Shear Loads^{1,2,3} for Threaded Rod Installed in Solid Concrete

THREADED ROD DIA. In. (mm)	DRILL HOLE DIAMETER In. (mm)	MAX. CLAMPING FORCE AFTER PROPER CURE Ft.-Lbs. (Nm)	EMBEDMENT IN CONCRETE In. (mm)	2000 PSI (13.8 MPa) CONCRETE		4000 PSI (27.6 MPa) CONCRETE	
				ULTIMATE TENSION Lbs. (kN)	ULTIMATE SHEAR Lbs. (kN)	ULTIMATE TENSION Lbs. (kN)	ULTIMATE SHEAR Lbs. (kN)
3/8 (9.5)	7/16 (11.1)	13 - 18 (17-24)	1-1/2 (38.1)	---	---	3,734 (16.6)	4,126 (18.3)
			3-3/8 (85.7)	5,852 (26.0)	5,220 (23.2)	10,977 (48.8)	5,220 (23.2)
			4-1/2 (114.3)	7,729 (34.4)	5,220 (23.2)	11,661 (51.9)	5,220 (23.2)
1/2 (12.7)	9/16 (14.3)	22 - 25 (29-33)	2 (50.8)	---	---	6,022 (26.8)	8,029 (35.7)
			4-1/2 (114.3)	10,798 (48.0)	8,029 (35.7)	17,162 (76.3)	8,029 (35.7)
			6 (152.4)	14,210 (63.2)	8,029 (35.7)	17,372 (77.3)	8,029 (35.7)
5/8 (15.9)	11/16 (17.5) or 3/4 (19.1)	55 - 80 (74-108)	2-1/2 (63.5)	---	---	7,330 (32.6)	11,256 (50.1)
			5-5/8 (142.9)	16,417 (73.0)	15,967 (71.0)	26,504 (117.9)	15,967 (71.0)
			7-1/2 (190.5)	18,747 (83.4)	15,967 (71.0)	29,381 (130.7)	15,967 (71.0)
3/4 (19.1)	13/16 (20.6) or 7/8 (22.2)	106 - 160 (143-216)	3 (76.2)	---	---	8,634 (38.4)	20,126 (89.5)
			6-3/4 (171.5)	18,618 (82.8)	20,126 (89.5)	29,727 (132.2)	20,126 (89.5)
			9 (228.6)	23,934 (106.5)	20,126 (89.5)	37,728 (167.8)	20,126 (89.5)
7/8 (22.2)	15/16 (23.8) or 1 (25.4)	185 - 250 (250-338)	3-1/2 (88.9)	---	---	13,650 (60.7)	20,920 (92.9)
			7-7/8 (200.0)	---	29,866 (132.9)	44,915 (199.8)	29,866 (132.9)
			10-1/2 (266.7)	36,881 (164.1)	29,866 (132.9)	48,321 (215.0)	29,866 (132.9)
1 (25.4)	1-1/16 (27.0) or 1-1/8 (28.6)	276 - 330 (374-447)	4 (101.6)	---	---	16,266 (72.2)	33,152 (147.5)
			9 (228.6)	32,215 (143.3)	37,538 (167.0)	48,209 (214.5)	37,538 (167.0)
			12 (304.8)	46,064 (143.3)	37,538 (167.0)	63,950 (284.5)	37,538 (167.0)
1-1/4 (31.8)	1-5/16 (33.3) or 1-3/8 (34.9)	370 - 660 (501-894)	5 (127.0)	---	---	21,838 (97.1)	33,152 (147.5)
			11-1/4 (285.8)	45,962 (204.5)	58,412 (259.8)	56,715 (252.3)	58,412 (259.8)
			15 (381.0)	62,208 (276.7)	58,412 (259.8)	84,385 (375.4)	58,412 (259.8)

1 Allowable working loads for the single installations under static loading should not exceed 25% capacity or the allowable load of the anchor rod.

2 Ultimate load values in 2000 and 4000 psi stone aggregate concrete. Ultimate loads are indicated for the embedment shown in the Embedment in Concrete column. Performance values are based on the use of high strength threaded rod (ASTM A193 Gr. B7). The use of lower strength rods will result in lower ultimate tension and shear loads.

3 Linear interpolation may be used for intermediate spacing and edge distances (see pages 14-15).

A7 Acrylic Adhesive Allowable Tension Loads¹ for Threaded Rod Installed in Solid Concrete

THREADED ROD DIA. In. (mm)	DRILL HOLE DIAMETER In. (mm)	MIN. EMBEDMENT DEPTH In. (mm)	ALLOWABLE TENSION LOAD BASED ON ADHESIVE BOND STRENGTH		ALLOWABLE TENSION LOAD BASED ON STEEL STRENGTH		
			2000 PSI (13.8 MPa) CONCRETE Lbs. (kN)	4000 PSI (27.6 MPa) CONCRETE Lbs. (kN)	ASTM A307 (SAE 1018) Lbs. (kN)	ASTM A193 GR. B7 (SAE 4140) Lbs. (kN)	AISI 304 SS Lbs. (kN)
3/8 (9.5)	7/16 (11.1)	1-1/2 (38.1)	---	934 (4.2)	2,080 (9.3)	4,340 (19.3)	3,995 (17.8)
		3-3/8 (85.7)	1,460 (6.5)	2,740 (12.2)	2,080 (9.3)	4,340 (19.3)	3,995 (17.8)
		4-1/2 (114.3)	1,930 (8.6)	2,915 (13.0)	2,080 (9.3)	4,340 (19.3)	3,995 (17.8)
1/2 (12.7)	9/16 (14.3)	2 (50.8)	---	1,505 (6.7)	3,730 (16.6)	7,780 (34.6)	7,155 (31.8)
		4-1/2 (114.3)	2,700 (12.0)	4,290 (19.1)	3,730 (16.6)	7,780 (34.6)	7,155 (31.8)
		6 (152.4)	3,550 (15.8)	4,340 (19.3)	3,730 (16.6)	7,780 (34.6)	7,155 (31.8)
5/8 (15.9)	11/16 (17.5) or 3/4 (19.1)	2-1/2 (63.5)	---	1,832 (8.2)	5,870 (26.1)	12,230 (54.4)	11,250 (50.0)
		5-5/8 (142.9)	4,100 (18.3)	6,625 (29.5)	5,870 (26.1)	12,230 (54.4)	11,250 (50.0)
		7-1/2 (190.5)	4,685 (20.8)	7,345 (32.7)	5,870 (26.1)	12,230 (54.4)	11,250 (50.0)
3/4 (19.1)	13/16 (20.6) or 7/8 (22.2)	3 (76.2)	---	2,158 (9.6)	8,490 (37.8)	17,690 (78.7)	14,860 (66.1)
		6-3/4 (171.5)	4,655 (20.7)	7,430 (33.1)	8,490 (37.8)	17,690 (78.7)	14,860 (66.1)
		9 (228.6)	5,980 (26.6)	9,430 (42.0)	8,490 (37.8)	17,690 (78.7)	14,860 (66.1)
7/8 (22.2)	15/16 (23.8) or 1 (25.4)	3-1/2 (88.9)	---	3,413 (15.2)	11,600 (51.6)	25,510 (113.5)	20,835 (92.7)
		7-7/8 (200.0)	---	11,230 (49.9)	11,600 (51.6)	25,510 (113.5)	20,835 (92.7)
		10-1/2 (266.7)	9,220 (41.0)	12,080 (53.7)	11,600 (51.6)	25,510 (113.5)	20,834 (92.7)
1 (25.4)	1-1/16 (27.0) or 1-1/8 (28.6)	4 (101.6)	---	4,067 (18.1)	15,180 (67.5)	31,620 (140.7)	26,560 (118.1)
		9 (228.6)	8,050 (35.8)	12,050 (53.6)	15,180 (67.5)	31,620 (140.7)	26,560 (118.1)
		12 (304.8)	11,515 (51.2)	15,985 (71.1)	15,180 (67.5)	31,620 (140.7)	26,560 (118.1)
1-1/4 (31.8)	1-5/16 (33.3) or 1-3/8 (34.9)	5 (127.0)	---	5,460 (24.3)	23,800 (105.9)	49,580 (220.6)	34,670 (154.2)
		11-1/4 (285.8)	11,490 (51.1)	14,175 (63.1)	23,800 (105.9)	49,580 (220.6)	34,670 (154.2)
		15 (381.0)	15,550 (69.2)	21,095 (93.8)	23,800 (105.9)	49,580 (220.6)	34,670 (154.2)

1 Use lower value of either bond or steel strength for allowable tensile load.

PERFORMANCE TABLE

 DRILL HOLE DIAMETERS
 PROVIDED ON PAGES 6-8

A7
Acrylic Adhesive
Allowable Shear Loads^{1,2} for Threaded Rod Installed in Solid Concrete

THREADED ROD DIA In. (mm)	DRILL HOLE DIAMETER In. (mm)	MIN. EMBEDMENT DEPTH In. (mm)	ALLOWABLE SHEAR LOAD BASED ON CONCRETE STRENGTH		ALLOWABLE SHEAR LOAD BASED ON STEEL STRENGTH		
			2000 PSI (13.8 MPa) CONCRETE Lbs. (kN)	4000 PSI (27.6 MPa) CONCRETE Lbs. (kN)	ASTM A307 (SAE 1018) Lbs. (kN)	ASTM A193 GR. B7 (SAE 4140) Lbs. (kN)	AISI 304 SS Lbs. (kN)
3/8 (9.5)	7/16 (11.1)	1-1/2 (38.1)	---	1,031 (4.6)	1,040 (4.6)	2,170 (9.7)	1,995 (8.9)
		3-3/8 (85.7)	1,305 (5.8)	1,305 (5.8)	1,040 (4.6)	2,170 (9.7)	1,995 (8.9)
1/2 (12.7)	9/16 (14.3)	2 (50.8)	---	2,005 (8.9)	1,870 (8.3)	3,895 (17.3)	3,585 (15.9)
		4-1/2 (114.3)	2,005 (8.9)	2,005 (8.9)	1,870 (8.3)	3,895 (17.3)	3,585 (15.9)
5/8 (15.9)	11/16 (17.5)	2-1/2 (63.5)	---	2,814 (12.5)	2,940 (13.1)	6,125 (27.2)	5,635 (25.1)
	or 3/4 (19.1)	5-5/8 (142.9)	3,990 (17.8)	3,990 (17.8)	2,940 (13.1)	6,125 (27.2)	5,635 (25.1)
3/4 (19.1)	13/16 (20.6)	3 (76.2)	---	5,030 (22.4)	4,250 (18.9)	8,855 (39.4)	7,440 (33.1)
	or 7/8 (22.2)	6-3/4 (171.5)	5,030 (22.4)	5,030 (22.4)	4,250 (18.9)	8,855 (39.4)	7,440 (33.1)
7/8 (22.2)	15/16 (23.8)	3-1/2 (88.9)	---	5,232 (23.3)	5,800 (25.8)	12,760 (56.8)	10,730 (47.7)
	or 1 (25.4)	7-7/8 (200.0)	7,465 (33.2)	7,465 (33.2)	5,800 (25.8)	12,760 (56.8)	10,730 (47.7)
1 (25.4)	1-1/16 (27.0)	4 (101.6)	---	8,288 (36.9)	7,590 (33.8)	15,810 (70.3)	13,285 (59.1)
	or 1-1/8 (28.6)	9 (228.6)	9,385 (41.7)	9,385 (41.7)	7,590 (33.8)	15,810 (70.3)	13,285 (59.1)
1-1/4 (31.8)	1-5/16 (33.3)	5 (127.0)	---	8,288 (36.9)	11,900 (52.9)	24,790 (100.3)	18,840 (83.8)
	or 1-3/8 (34.9)	11-1/4 (285.8)	14,600 (64.9)	14,600 (64.9)	11,900 (52.9)	24,790 (100.3)	18,840 (83.8)

1 Use lower value of either concrete or steel strength for allowable shear load.

2 Allowable loads taken from ICC Evaluation Report #5560 (formerly ICBO).

PERFORMANCE TABLE
A7
Acrylic Adhesive
Average Ultimate Tension and Shear Loads^{1,2} for Threaded Rod Installed in Grout Filled Concrete Block

THREADED ROD DIA. In. (mm)	DRILL HOLE DIAMETER In. (mm)	EMBEDMENT DEPTH In. (mm)	ANCHOR LOCATION	ULTIMATE TENSION Lbs. (kN)	ULTIMATE SHEAR Lbs. (kN)
1/2 (12.7)	5/8 (15.9)	4-1/4 (108.0)	GROUTED CELL	5,170 (23.0)	8,500 (37.8)
5/8 (15.9)	3/4 (19.1)	5 (127.0)	GROUTED CELL	6,320 (28.1)	10,850 (48.3)
3/4 (19.1)	7/8 (22.2)	6-5/8 (168.3)	GROUTED CELL	10,910 (48.5)	17,075 (76.0)

1 Allowable working loads for the single installations should not exceed 25% (an industry standard) capacity or the allowable load of the anchor rod. Loads based upon testing with ASTM A193, Grade B7 rods.

2 The tabulated values are for anchors installed at minimum 12 inch edge distance and minimum 8 inch spacing.

PERFORMANCE TABLE
A7
Acrylic Adhesive
Average Ultimate Tension and Shear Loads¹ for Threaded Rod Installed in Grouted² Brick Masonry Constructed of Solid Red Brick Units

THREADED ROD DIA. In. (mm)	DRILL HOLE DIAMETER In. (mm)	EMBEDMENT DEPTH In. (mm)	ANCHOR LOCATION	ULTIMATE TENSION Lbs. (kN)	ULTIMATE SHEAR Lbs. (kN)
1/4 (6.4)	3/8 (9.5)	3-1/2 (88.9)	CENTER OF BRICK FACE	2,130 (9.5)	1,165 (5.2)
		6 (152.4)	CENTER OF BRICK FACE	3,575 (15.9)	1,550 (6.9)
3/8 (9.5)	1/2 (12.7)	3-1/2 (88.9)	CENTER OF BRICK FACE	2,130 (9.5)	4,150 (18.5)
		6 (152.4)	CENTER OF BRICK FACE	8,875 (39.5)	6,950 (30.9)
1/2 (12.7)	5/8 (15.9)	3-1/2 (88.9)	CENTER OF BRICK FACE	2,130 (9.5)	3,090 (13.7)
		6 (152.4)	CENTER OF BRICK FACE	12,155 (54.1)	7,910 (35.2)

1 Allowable working loads for the single installations should not exceed 25% (an industry standard) capacity or the allowable load of the anchor rod. Loads based upon testing with ASTM A193, Grade B7 rods.

2 Void between brick wythes was grouted solid; therefore the use of screens was not necessary.

A7 Adhesive for Sill Plate Attachments

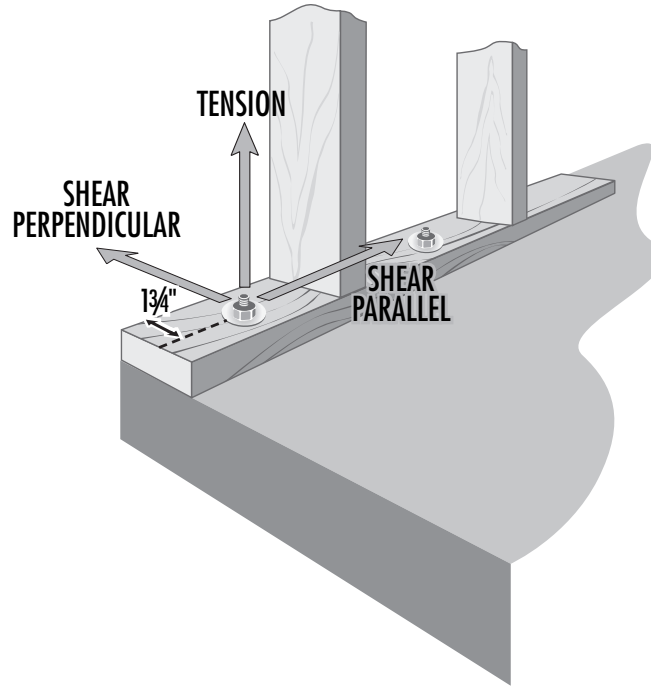

PERFORMANCE TABLE

A7 Acrylic Adhesive Average Ultimate Tension and Shear^{1,2,3} for Threaded Rods in Solid Concrete Floors and Stemwalls at 1-3/4" Edge Distance

ANCHOR DIAMETER	DRILL HOLE DIAMETER In. (mm)	EMBEDMENT In. (mm)	2000PSI (13.8 MPa) CONCRETE		
			SHEAR LOAD DIRECTION	ULTIMATE TENSION Lbs. (kN)	ULTIMATE SHEAR Lbs. (kN)
1/2 (12.7)	9/16 (14.3)	4-1/2 (114.3)	Perpendicular	9,180 (40.8)	1,760 (7.8)
			Parallel	9,180 (40.8)	7,240 (32.2)
5/8 (15.9)	11/16 (17.5) or 3/4 (19.1)	5-5/8 (142.9)	Perpendicular	13,620 (60.6)	2,540 (11.3)
			Parallel	13,620 (60.6)	8,778 (39.0)
	10 (254.0)	Perpendicular	20,700 (92.1)	2,540 (11.3)	
		Parallel	20,700 (92.1)	8,799 (39.1)	
3/4 (19.1)	13/16 (20.6) or 7/8 (22.2)	6-3/4 (171.4)	Perpendicular	15,080 (67.1)	2,080 (9.2)
			Perpendicular	29,940 (133.2)	2,080 (9.2)
7/8 (22.2)	15/16 (23.8) or 1 (25.4)	15 (381.0)	Perpendicular	29,940 (133.2)	2,080 (9.2)
			Parallel	29,940 (133.2)	7,101 (31.6)

1 Allowable working loads for the single installations under static loading should not exceed 25% capacity or the allowable load of the anchor rod.

2 Ultimate load values in 2000 and 4000 psi stone aggregate concrete. Ultimate loads are indicated for the embedment shown in the Embedment in Concrete column. Performance values are based on the use of high strength threaded rod (ASTM A193 Gr. B7). The use of lower strength rods will result in lower ultimate tension and shear loads.

3 Linear interpolation may be used for intermediate spacing and edge distances (see pages 14-15).

PERFORMANCE TABLE

A7 Acrylic Adhesive

Allowable Tension Loads^{1,2} at 1-3/4" Edge Distance for Threaded Rods in Solid Concrete Floors and Stemwalls

DIAMETER In. (mm)	DRILL HOLE DIAMETER In. (mm)	EMBEDMENT DEPTH In. (mm)	2000 PSI (13.8 MPa) CONCRETE Lbs. (kN)	ALLOWABLE TENSION LOAD BASED ON STEEL STRENGTH		
				ASTM A307 (SAE 1018) Lbs. (kN)	ASTM A193 GR. B7 (SAE 4140) Lbs. (kN)	AISI 304 SS Lbs. (kN)
1/2 (12.7)	9/16 (14.3)	4-1/2 (114.3)	2,295 (10.2)	3,730 (16.6)	7,780 (34.6)	7,155 (31.8)
5/8 (15.9)	11/16 (17.5)	5-5/8 (142.9)	3,405 (10.7)	5,870 (26.1)	12,230 (54.4)	11,250 (50.0)
	or 3/4 (19.1)	10 (254.0)	5,175 (23.0)	5,870 (26.1)	12,230 (54.4)	11,250 (50.0)
3/4 (19.1)	13/16 (20.6) or 7/8 (22.2)	6-3/4 (171.4)	3,770 (16.8)	8,490 (37.8)	17,690 (78.7)	14,860 (66.1)
7/8 (22.2)	15/16 (23.8) or 1 (25.4)	15 (381.0)	7,485 (33.3)	11,600 (51.6)	25,510 (113.5)	20,835 (92.7)

1 Use lower value of either bond or steel strength for allowable tensile load.

2 Linear interpolation may be used for intermediate spacing and edge distances (see pages 14-15).

PERFORMANCE TABLE

A7 Acrylic Adhesive

Allowable Shear Loads¹ at 1-3/4" Edge Distance for Threaded Rods in Solid Concrete Floors and Stemwalls

DIAMETER In. (mm)	DRILL HOLE DIAMETER In. (mm)	EMBEDMENT DEPTH In. (mm)	SHEAR LOAD DIRECTION	2000 PSI (13.8 MPa) CONCRETE Lbs. (kN)	ALLOWABLE SHEAR LOAD BASED ON STEEL STRENGTH		
					ASTM A307 (SAE 1018) Lbs. (kN)	ASTM A193 GR. B7 (SAE 4140) Lbs. (kN)	AISI 304 SS Lbs. (kN)
1/2 (12.7)	9/16 (14.3)	4-1/2 (114.3)	Perpendicular	440 (1.9)	1,870 (8.3)	3,895 (17.3)	3,585 (15.9)
			Parallel	1,810 (8.0)	1,870 (8.3)	3,895 (17.3)	3,585 (15.9)
5/8 (15.9)	11/16 (17.5) or 3/4 (19.1)	5-5/8 (142.9)	Perpendicular	635 (2.8)	2,940 (13.1)	6,125 (27.2)	5,635 (25.1)
			Parallel	2,195 (9.8)	2,940 (13.1)	6,125 (27.2)	5,635 (25.1)
		10 (254.0)	Perpendicular	635 (2.8)	2,940 (13.1)	6,125 (27.2)	5,635 (25.1)
			Parallel	2,200 (9.8)	2,940 (13.1)	6,125 (27.2)	5,635 (25.1)
3/4 (19.1)	13/16 (20.6) or 7/8 (22.2)	6-3/4 (171.4)	Perpendicular	600 (2.7)	4,250 (18.9)	8,855 (39.4)	7,440 (33.1)
7/8 (22.2)	15/16 (23.8) or 1 (25.4)	15 (381.0)	Perpendicular	520 (2.3)	5,800 (25.8)	12,760 (56.8)	10,730 (47.7)
			Parallel	1,775 (7.9)	5,800 (25.8)	12,760 (56.8)	10,730 (47.7)

1 Use lower value of either concrete or steel strength for allowable shear load.

PERFORMANCE TABLE

 DRILL HOLE DIAMETERS
 PROVIDED ON PAGES 6-8

A7
Acrylic Adhesive
**Average Ultimate Tension Loads^{1,2,3} for Reinforcing Bar
 Installed in Solid Concrete**

REINFORCING BAR DIA. In. (mm)	EMBEDMENT IN CONCRETE In. (mm)	2000 PSI (13.8 MPa) CONCRETE		4000 PSI (27.6 MPa) CONCRETE		ULTIMATE TENSILE AND YIELD STRENGTH GRADE 60 REBAR			
		ULTIMATE TENSION Lbs. (kN)		ULTIMATE TENSION Lbs. (kN)		MINIMUM YIELD STRENGTH Lbs. (kN)		MINIMUM ULTIMATE TENSILE STRENGTH Lbs. (kN)	
# 3 (9.5)	3-3/8 (85.7)	6,180 (27.5)	8,324 (37.0)	6,600 (29.4)	9,900 (44.0)	6,600 (29.4)	9,900 (44.0)	6,600 (29.4)	9,900 (44.0)
	4-1/2 (114.3)	7,560 (33.6)	11,418 (50.8)	6,600 (29.4)	9,900 (44.0)				
# 4 (12.7)	4-1/2 (114.3)	9,949 (44.3)	16,657 (74.1)	12,000 (53.4)	18,000 (80.1)	12,000 (53.4)	18,000 (80.1)	12,000 (53.4)	18,000 (80.1)
	6 (152.4)	15,038 (66.9)	17,828 (79.3)	12,000 (53.4)	18,000 (80.1)				
# 5 (15.9)	5-5/8 (142.9)	14,012 (62.3)	20,896 (93.0)	18,600 (82.7)	27,900 (124.1)	18,600 (82.7)	27,900 (124.1)	18,600 (82.7)	27,900 (124.1)
	7-1/2 (190.5)	16,718 (74.4)	26,072 (116.0)	18,600 (82.7)	27,900 (124.1)				
# 6 (19.1)	6-3/4 (171.5)	21,247 (94.5)	26,691 (118.7)	26,400 (117.4)	39,600 (176.2)	26,400 (117.4)	39,600 (176.2)	26,400 (117.4)	39,600 (176.2)
	9 (228.6)	33,325 (148.2)	37,425 (166.5)	26,400 (117.4)	39,600 (176.2)				
# 7 (22.2)	7-7/8 (200.0)	--	40,374 (179.6)	36,000 (160.1)	54,000 (240.2)	36,000 (160.1)	54,000 (240.2)	36,000 (160.1)	54,000 (240.2)
	10-1/2 (266.7)	38,975 (173.4)	46,050 (204.8)	36,000 (160.1)	54,000 (240.2)				
# 8 (25.4)	9 (228.6)	35,600 (158.4)	47,311 (210.5)	47,400 (210.9)	71,100 (316.3)	47,400 (210.9)	71,100 (316.3)	47,400 (210.9)	71,100 (316.3)
	12 (304.8)	41,010 (182.4)	66,140 (294.2)	47,400 (210.9)	71,100 (316.3)				
# 9 (28.6)	10-1/8 (257.2)	--	57,221 (254.5)	60,000 (266.9)	90,000 (400.4)	60,000 (266.9)	90,000 (400.4)	60,000 (266.9)	90,000 (400.4)
	13-1/2 (342.9)	--	79,966 (355.7)	60,000 (266.9)	90,000 (400.4)				
# 10 (31.8)	11-1/4 (285.8)	49,045 (218.2)	73,091 (325.1)	76,200 (339.0)	114,300 (508.5)	76,200 (339.0)	114,300 (508.5)	76,200 (339.0)	114,300 (508.5)
	15 (381.0)	69,079 (307.3)	83,295 (370.5)	76,200 (339.0)	114,300 (508.5)				
# 11 (34.9)	12-3/8 (314.3)	63,397 (282.0)	75,047 (333.8)	93,600 (416.4)	140,400 (624.6)	93,600 (416.4)	140,400 (624.6)	93,600 (416.4)	140,400 (624.6)
	16-1/2 (419.1)	81,707 (363.5)	91,989 (409.2)	93,600 (416.4)	140,400 (624.6)				

1 Allowable working loads for the single installations under static loading should not exceed 25% capacity or the allowable load of the anchor rod.

2 Ultimate load values in 2000 and 4000 psi stone aggregate concrete. Ultimate loads are indicated for the embedment shown in the Embedment in Concrete column. Performance values are based on the use of minimum Grade 60 reinforcing bar. The use of lower strength rods will result in lower ultimate tension loads.

3 SHEAR DATA: Provided the distance from the rebar to the edge of the concrete member exceeds 1.25 times the embedment depth of the rebar, calculate the ultimate shear load for the rebar anchorage as 60% of the ultimate tensile strength of the rebar.

PERFORMANCE TABLE
A7
Acrylic Adhesive
**Recommended Edge Distance Requirements for
 Shear Loads**

ANCHOR DIAMETER In. (mm)	EMBEDMENT DEPTH In. (mm)	CRITICAL EDGE DISTANCE In. (mm) (100% LOAD CAPACITY)	INTERPOLATED EDGE DISTANCE In. (mm) (80% LOAD CAPACITY)	INTERPOLATED EDGE DISTANCE In. (mm) (50% LOAD CAPACITY)	MINIMUM EDGE DISTANCE In. (mm) (10% LOAD CAPACITY)
3/8 (9.5)	3-3/8 (85.7)	4-3/16 (106.4)	3-7/16 (87.3)	2-5/16 (58.7)	13/16 (20.6)
1/2 (12.7)	4-1/2 (114.3)	5-5/8 (142.9)	4-5/8 (117.5)	3-1/8 (79.4)	1-1/8 (28.6)
5/8 (15.9)	5-5/8 (142.9)	7 (177.8)	5-3/4 (146.1)	3-1/8 (79.4)	1-3/8 (34.9)
3/4 (19.1)	6-3/4 (171.5)	8-7/16 (214.2)	6-15/16 (176.2)	4-5/8 (117.5)	1-5/8 (41.3)
1 (25.4)	9 (228.6)	11-1/4 (285.8)	9-1/4 (235.0)	6-1/4 (158.8)	2-1/4 (57.2)
1-1/4 (31.8)	11-1/4 (285.8)	14-1/16 (357.2)	11-5/8 (295.3)	7-7/8 (200.0)	2-7/8 (73.0)

Combined Shear and Tension Loading—for A7 Adhesive Anchors

Allowable loads for anchors under tension and shear loading at the same time (combined loading) will be lower than the allowable loads for anchors subjected to 100% tension or 100% shear. Use the following equation to evaluate anchors in combined loading conditions:

$$\left(\frac{N_a}{N_s}\right)^{5/3} + \left(\frac{V_a}{V_s}\right)^{5/3} \leq 1$$

 N_a = Applied Service Tension Load
 N_s = Allowable Tension Load

 V_a = Applied Service Shear Load
 V_s = Allowable Shear Load

PERFORMANCE TABLE

A7 Recommended Edge Distance Requirements for Acrylic Adhesive Tension Loads

ANCHOR DIAMETER In. (mm)	EMBEDMENT DEPTH In. (mm)	CRITICAL EDGE DISTANCE In. (mm) (100% LOAD CAPACITY)	INTERPOLATED EDGE DISTANCE In. (mm) (90% LOAD CAPACITY)	INTERPOLATED EDGE DISTANCE In. (mm) (80% LOAD CAPACITY)	MINIMUM EDGE DISTANCE In. (mm) (70% LOAD CAPACITY)
3/8 (9.5)	3-3/8 (85.7)	2-1/2 (63.5)	1-15/16 (49.2)	1-3/8 (34.9)	13/16 (26.2)
	4-1/2 (114.3)	3-3/8 (85.7)	2-5/8 (66.7)	1-7/8 (47.6)	1-1/8 (28.6)
1/2 (12.7)	4-1/2 (114.3)	3-3/8 (85.7)	2-5/8 (66.7)	1-7/8 (47.6)	1-1/8 (28.6)
	6 (152.4)	4-1/2 (114.3)	3-1/2 (88.9)	2-1/2 (63.5)	1-1/2 (38.1)
5/8 (15.9)	5-5/8 (142.9)	4-3/16 (106.4)	3-1/4 (82.6)	2-5/16 (58.7)	1-3/8 (34.9)
	7-1/2 (190.5)	5-5/8 (142.9)	4-3/8 (111.1)	3-1/8 (79.4)	1-7/8 (47.6)
3/4 (19.1)	6-3/4 (171.5)	5-1/16 (128.6)	3-15/16 (100.0)	2-13/16 (71.4)	1-5/8 (15.9)
	9 (228.6)	6-3/4 (171.5)	5-1/4 (133.4)	3-3/4 (95.3)	2-1/4 (57.2)
1 (25.4)	9 (228.6)	6-3/4 (171.5)	5-1/4 (133.4)	3-3/4 (95.3)	2-1/4 (57.2)
	12 (304.8)	9 (228.6)	7 (177.8)	5 (127.0)	3 (76.2)
1-1/4 (31.8)	11-1/4 (285.8)	8-7/16 (214.3)	6-9/16 (166.7)	4-3/4 (120.7)	2-7/8 (73.0)
	15 (381.0)	11-1/4 (285.8)	8-3/4 (222.2)	6-1/4 (158.8)	3-3/4 (95.3)

PERFORMANCE TABLE

A7 Recommended Spacing Requirements for Acrylic Adhesive Tension Loads

ANCHOR DIAMETER In. (mm)	EMBEDMENT DEPTH In. (mm)	CRITICAL SPACING In. (mm) (100% LOAD CAPACITY)	INTERPOLATED SPACING In. (mm) (90% LOAD CAPACITY)	MINIMUM SPACING In. (mm) (80% LOAD CAPACITY)
3/8 (9.5)	3-3/8 (85.7)	4-3/16 (106.4)	2-1/2 (63.5)	13/16 (20.6)
	4-1/2 (114.3)	5-5/8 (142.9)	3-3/8 (85.7)	1-1/8 (28.6)
1/2 (12.7)	4-1/2 (114.3)	5-5/8 (142.9)	3-3/8 (85.7)	1-1/8 (28.6)
	6 (152.4)	7-1/2 (190.5)	4-1/2 (114.3)	1-1/2 (38.1)
5/8 (15.9)	5-5/8 (142.9)	7 (177.8)	4-3/16 (106.4)	1-3/8 (34.9)
	7-1/2 (190.5)	9-3/8 (238.1)	5-5/8 (142.9)	1-7/8 (47.6)
3/4 (19.1)	6-3/4 (171.5)	8-7/16 (214.3)	5 (127.0)	1-5/8 (41.3)
	9 (228.6)	11-1/4 (285.8)	6-3/4 (171.5)	2-1/4 (57.2)
1 (25.4)	9 (228.6)	11-1/4 (285.8)	6-3/4 (171.5)	2-1/4 (57.2)
	12 (304.8)	15 (381.0)	9 (228.6)	3 (76.2)
1-1/4 (31.8)	11-1/4 (285.8)	14-1/16 (357.2)	8-1/2 (215.9)	2-7/8 (73.0)
	15 (381.0)	18-3/4 (476.3)	11-1/4 (285.8)	3-3/4 (95.5)

A7 Adhesive Anchoring System Spacing/Edge Distance Load Factor Summary¹

LOAD FACTOR
Critical Edge Distance—Tension

100% Tension Load → 0.75 x Anchor Embedment (or greater)

Minimum Edge Distance—Tension

70% Tension Load → 0.25 x Anchor Embedment

Critical Edge Distance—Shear

100% Shear Load → 1.25 x Anchor Embedment (or greater)

Minimum Edge Distance—Shear

10% Shear Load → 0.25 x Anchor Embedment

LOAD FACTOR
Critical Spacing—Tension

100% Tension Load → 1.25 x Anchor Embedment (or greater)

Minimum Spacing—Tension

80% Tension Load → 0.25 x Anchor Embedment

DISTANCE FROM EDGE OF CONCRETE
DISTANCE FROM ANOTHER ANCHOR
¹ Use linear interpolation for load factors at edge distances or spacing distances between critical and minimum.

A7 Chemical Resistance

A7 Chemical Resistance		HIGH Anchors installed with A7 could be submerged in these materials.	MEDIUM Intermittent exposure or temporary submersion due to splash or spill.	LOW Exposure of A7 should be limited to splash and spill exposure followed by immediate cleanup.
Fresh Water		✓		
Salt Water		✓		
Brine		✓		
Urine		✓		
Humus		✓		
20% Caustic (NaOH)			✓	
Gasoline			✓	
10% Sulfuric Acid (H ₂ SO ₄)			✓	
3.5% Hydrochloric Acid (HCl)			✓	
9% Phosphoric Acid (H ₃ PO ₄)			✓	
10% Nitric Acid			✓	
8.5% Ammonium Hydroxide			✓	
Bleach			✓	
Ammonia			✓	
Xylene				✓
Toluene				✓
Acetone				✓
Glacial Acetic Acid				✓
Methanol				✓
Methylene Chloride				✓

Important Note: This chemical resistance table above applies only when A7 adhesive is used for installing anchors into concrete in a conventional manner with recommended hole sizes. Installation of the anchor must always be done in a drilled hole which is completely cleaned of all concrete dust. Exposure to solvents and chemicals, as listed above should occur only after the A7 adhesive has fully cured.